

# METRIX

## Experience Value



440/450 electronic switches utilize a solid state crystal accelerometer which provides an electrical output when it is deformed by the vibration forces. The output is electronically converted to a signal proportional to velocity. This signal is compared with a preset limit and triggers a solid state relay if the limit is exceeded. There are no moving parts in the 440 vibration switches except when configured with mechanical relays.

While the 440 costs more than a mechanical switch, it uses the same technology as sophisticated remote monitoring systems and provides most of the capabilities of these systems at 1/3 to 1/2 the cost per monitor point.

An important feature of these switches is the built-in time delay. This prevents triggering of the alarm or shutdown functions from transient increases in vibration levels. It also avoids shutdown due to transitory vibrations occurring during start-up.

Almost all machines experience a few seconds of high vibration during start-up before reaching operating speed. When no time delay function is included, as with mechanical switches, this start-up vibration causes a trip. Frequently, the operator turns the trip setting up until he can get through start-up. The resultant trip level is too high to afford protection at the machine's operating speed.

Three-second alarm trip delay is standard on these electronic switches. Alarm time delays are independently adjustable in the field over a range of 2 to 15 seconds.

### Features

- Built-in alarm time delay
- Reduce false triggering
- Velocity triggering provides protection at all frequencies
- Sensitivity is not affected by rotating speed of machinery
- Analog dial for setting limits
- Solid state relay contacts used for alarm and/or shutdown
- Field settable for N.O. or N.C.
- Remote reset capability
- Provision for self-test and calibration
- 4-20 mA output available
- Built-in transducer or optional remote transducer
- Cast aluminum enclosures meet NEMA 3, 4 and 12 standards
- Explosion-proof models (450 Series) available

Built-in piezoelectric transducer module with integral amplifier provides 2 to 1,000 Hz capability.



Calibrated set point controls enable operator to set specific velocity trip points.

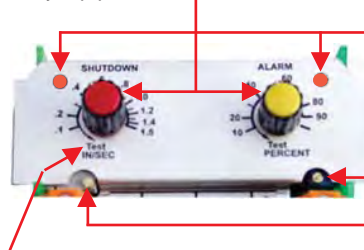

Light comes on immediately when vibration exceeds set point (alarm or shutdown will trip after 3 second time delay).

Adjustable time delay of 2-15 seconds. Factory set at 3 seconds.

Test position sets in minimum set point so that any vibration will cause trip condition. Light will come on immediately, and trip will occur after duration of the time delay, proving that the complete system is operational. If test position is maintained for less than the duration of the time delay, trip will not occur, thus permitting system test without shutdown.

VDE approved terminal strip accepts #12 wire. Screw adjustable clamping yoke rather than screw terminal permits easy, vibration proof connection. All hardware is captive.

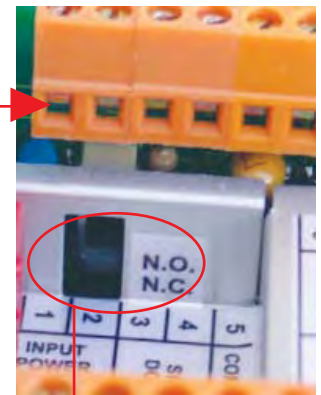

Each solid-state contact is independently field settable to open on alarm (N.C.) or close on alarm (N.O.).

440 & 450 Electronic Vibration Switch

SWITCHES

## Specifications

### No. of Trips:

440DR: TWO: One for alarm and one for shutdown.  
Shutdown set in in/sec (velocity model).

### Analog Output for Trending and Remote Indication:

440SR & 440DR:  $\pm 10\%$  accuracy over 4-20 mA DC range.

Absolute Option: 4 mA = 0 vibration; 20 mA = Full scale range of switch.

Termination load resistance, less than 450 ohms.

**Velocity Set Point:** 0.1 to 1.5 in/sec or 0.2 to 3 in/sec peak. Metric ranges: 3 to 40 mm/sec or 6 to 80 mm/sec peak

**Frequency Range:** 2 to 1000 Hz

**Time Delay:** Field adjustable 2-15 sec. Factory set for 3 sec unless specified otherwise

### Alarm or Shutdown Output(s):

Solid state relay (triac). Two in 440DR. Isolated (dry) contact. Each triac field settable for close on alarm (N.O.) or open on alarm (N.C.). 5 A continuous, 100A for 10 msec.

Max. off-state leakage current: 1 mA

Min holding current: 50 mA typical

Max. voltage across SS relay: 140VAC (280VAC on 230V input units)

**NOTE:** If the relay output is connecting to a PLC or DCS, DO NOT use 5A Triac. See How To Select D & E.

**Remote Reset:** Connection between terminals 5 and 6 latches triac output in alarm state after setpoint is exceeded. Opening the connection will reset the output to non-alarm state.

**Set Point Accuracy:**  $\pm 10\%$  of setting with repeatability of  $\pm 2\%$ . Circuitry utilizes RMS detector

**Vibration Sensitive Axis:** Perpendicular to base. Unit can be mounted in any orientation without affecting setting

**Temperature Limits:** -20°F to +140°F (-30°C to +60°C) including internal transducer. -65°F to +190°F (-55°C to +88°C) for optional external transducer

**Humidity:** 1% to 100% (non-condensing)

**Input Power:** 100-130 VAC 50/60 Hz standard. 200-260 VAC 50/60 Hz optional. DC input power optional.

**Enclosure:** Rugged, water-tight, dust-tight, cast aluminum. Meets NEMA, 3, 4 and 12 standards. Optional CSA mark for Class I, Div 2, Grps B-D, Or explosion-proof Model 450. 440 - NEMA 4X.

**Weight:** 440 - 1.6 kg (3.5 lbs); 450 - 2.72 kg (6 lbs)

**Mounting:** 1/4" hardware, 3 mounting bosses

**Terminals:** All terminals will accept #12 AWG wire in clamping type yoke without need for termination hardware. ALL hardware is captive.

**Self Test:** Test position on set point control and light emitting diode provide functional test of trip circuitry, time delay and triac closure. Also permits on-line calibration of switch.

**Circuitry:** Proprietary hybrid circuitry throughout for minimum size and maximum reliability in vibration environment.

**Remote Transducer Option:** The standard 440 includes a built-in transducer. A separate transducer can be specified. Please request separate transducer when placing order. See How To Select page. The SA6200 accelerometer (100 mV/g) is recommended.

## Weight & Dimensions

**Weight: 1.6 kg [3.5 lbs]**  
Dimensions in mm [inches]

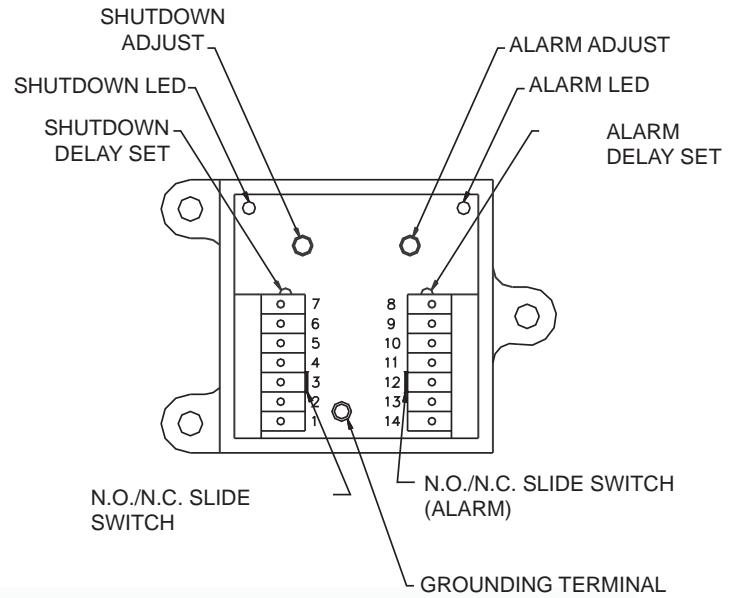

**NOTE:**  
For single limit units, shutdown output is used.

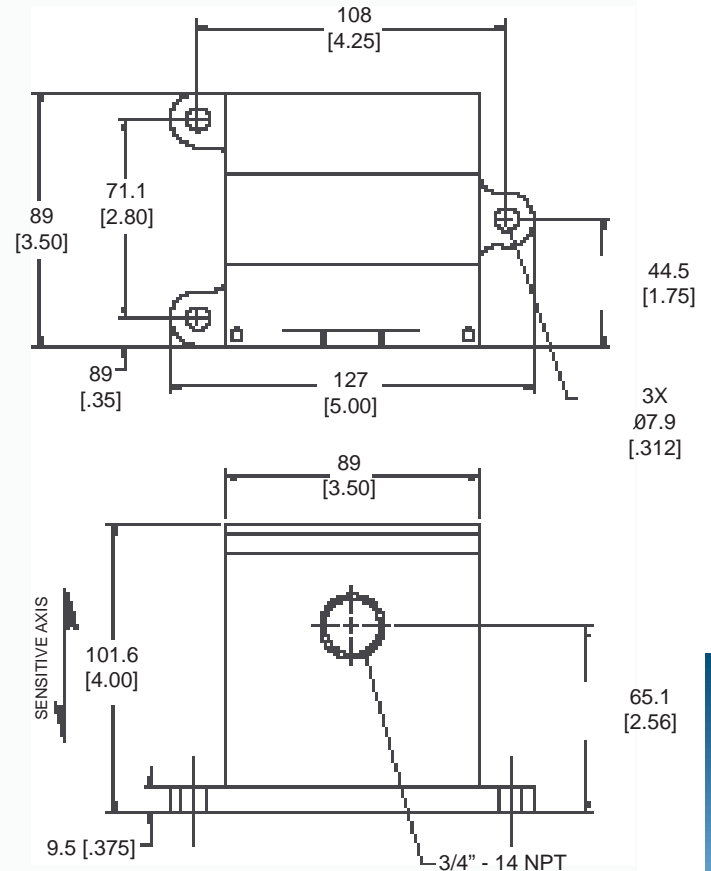

# How To Select

Special modifications and options will receive an "M" number, assigned by the factory.

**Model 440 - Epoxy coated NEMA 4x, and CSA Class I, Div. 2, Grps B-D except w/ mechanical relays and external transducer**

**Model 450 - Painted finish, and CSA, Class I, Div. 1, Grps B-D; Class II, Grps, E-G**

\*\*Epoxy coated NEMA 4x available

440  A -  B  C  D  E -  F  G  H  I

450  A -  B  C  D  E -  F  G  H  I

A  Single or Dual Trip/Analog Signal Output

SR	= Single Trip, Analog Signal Output
DR	= Dual Trip, Analog Signal Output

B  Analog Signal Output

2	= 4-20 mA, absolute (recommended)
---	-----------------------------------

C  Scale

0	= 0.1 - 1.5 in/sec
1	= 0.2 - 3.0 in/sec
2	= 3 - 40 mm/sec
3	= 6 - 80 mm/sec

D  Shutdown Circuit\*

0	= Triac, 5A, SPST (for switching heavy AC loads)
2	= 170 mA, 250 Volts, Pk, analog, SPST switch, good selection for use with PLC or DCS
4	= 10A SPDT Relay

\*Note: Except on 440 Series for Mechanical Relay.

E  Alarm Circuit (Always 0 if A = SR)

1	= Triac, 5A Standard
2	= 170 mA, 250 Volts Pk, Analog SPST Switch (Use for PLC or DCS)
4	= 10A SPDT Relay

F  Enclosure

0	= Standard, CSA, Class I, Div 2, Grps B-D* (440)
---	--------------------------------------------------

\*Note: Except on 440 Series for mechanical relays, external transducers and BNC connectors.

G  Input Power

0	= 115 Vac, 50/60 Hz
1	= 230 Vac, 50/60 Hz
2	= 24 Vdc ± 10%

H  Lockout Function

0	= None
2	= 20 second start-up delay

I  External Transducer Option

0	= Internal
5	= SA6200A Constant Current Accelerometer with 7295 Housing Recommended



Model 440DR  
NEMA 4, Class I, Div. 2, Grps. B,C & D



Model 450SR  
Class I, Div. 1, Grps. B, C & D



Note: Model SA6200A (mV/g) is recommended for use with 440-450 switches.

Please contact factory for options and pricing.

**Model 440DR/450DR (Dual Trip w/4-20 mA output)**

One limit for alarm, a second limit for shutdown, and 4-20 mA output for remote vibration readout or computer interface.

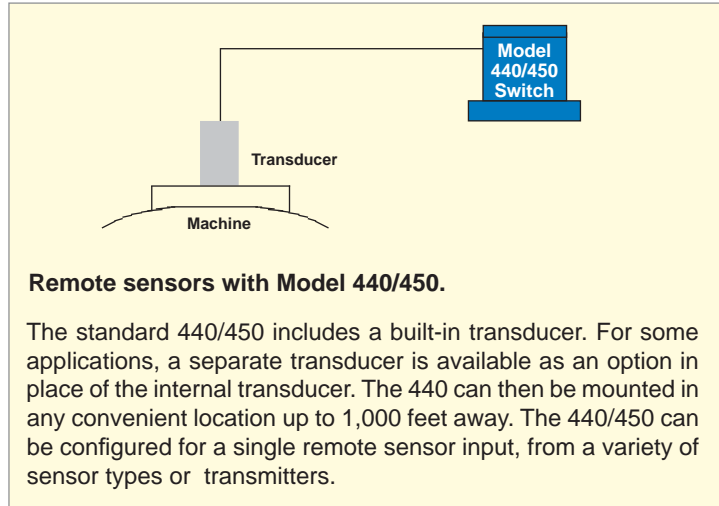

**Single or Dual Trip Switches Provide Early Warning**

The Model 440SR provides a single switch closure which can be used for alarm or shutdown. However, it is often desired to provide a warning before shutdown. The Model 440DR is ideal for this requirement. It provides two trips: one for alarm and one for shutdown.

The first trip is set at a vibration alarm level to provide early warning that the condition of the machine is deteriorating. When the alarm trip occurs, the operator can evaluate the condition and schedule corrective maintenance - at a time that does not interrupt the production schedule. If the machine condition continues to deteriorate, the shutdown trip provides protection against catastrophic failure.

**The 440/450 as a Vibration Transmitter**

The 4-20 mA output available on the model 440SR and 440DR can be utilized to drive a remote display or to interface to a PLC or other plant computer for trending of vibration. For trending applications the ABSOLUTE analog output option is recommended. In this configuration 20 mA is equal to the full scale range of the switch.

**Velocity Trip**

The different causes of machinery failure (imbalance, misalignment, bearings, etc.) result in increased vibration at different frequencies (CPM) on a given machine. Therefore, it is important that the vibration protection device be equally

sensitive to damaging vibration at all frequencies.

International standards for rotating machinery (ISO 2372, 3945) specify that vibration severity is directly related to vibratory velocity. The PMC/BETA 440/450 series electronic vibration switches measure and trip on velocity.

In mechanical switches, sensing and tripping are inherently limited to impact/acceleration. Since severity (damage potential) is proportional to velocity, acceleration tripping is oversensitive to some frequencies and not sensitive enough to others - with the result of either false trips in some cases, or not enough protection in others.

**Why Use Remote Sensors**

Vibration switches can be configured to work with external sensors (accelerometers). When an external sensor is used, the internal accelerometer is not present.

Mounting location size, temperature considerations, vibrating environment and application would determine when to use an external sensor. For example, if the vibration switch is too large to fit a machine location, consider using a remote accelerometer and an interconnecting cable.

**Typical Installations**

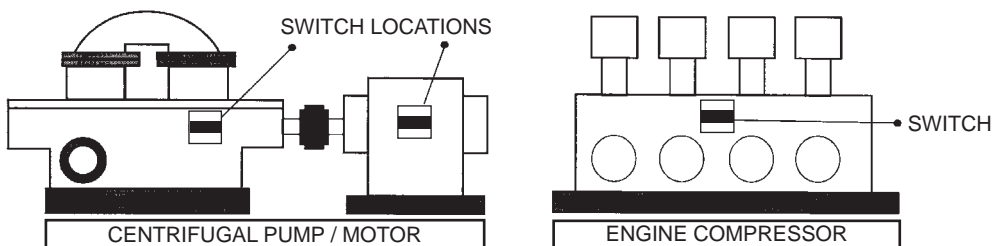

## Available Transducers



SA6200A Accelerometer, available with two pin MS style connector or integrated cable. Replaces 160 A & E.



7295-002 Accelerometer EP Housing, provides physical protection and access to 1/4"-28 mount accelerometers.

## Mating Connector/Cable Assemblies



### 8978-111-XXXX, Splashproof Cable Assembly\*

Two (2) pin socket connector with integral, molded splash proof boot with 6.4 mm (0.25") diameter polyurethane jacketed cable with twisted shielded pair wires. xxx.x = Cable length in meters.



### 9334-111-XXXX-YYYY, Splashproof Cable Assembly w/Stainless Steel Armor\*

Two (2) pin socket connector with integral, molded splash proof boot with 7.1 mm (0.28") diameter, SST armored jacket with cable, twisted shielded pair wires. xxx.x = Armor length in meters. yyy.y = Cable length in meters.



### 8978-200-0000, Connector Assembly

Two (2) pin socket connector with cable strain relief, no cable.

\*Note: Constant current type accelerometers with 2 pin MS connectors.

## 450 Weight & Dimensions

