



11mm Proximity Probe TM0110 System

Linear range

The 11mm probe has up to 4mm (160mil) linear range. The TM0110 probe is recommended when a longer linear range is required. The TM0110 proximity probe system is designed to meet API 670 industrial standard. The system consists of a probe, extension cable and driver. In most cases, ProvibTech's transmitters (DTM and TR series) and dual monitors (DM series) directly interface with a probe and extension cable, eliminating the need of a driver.

Components of TM0110 system

Proximity Probe – TM0110

The TM0110 probe is an 11mm probe designed for harsh environments. The rugged cable jacket helps prevent the probe cable from breaking and tearing, as well as, being highly resistive to corrosive environments. The TM0110 proximity probe and extension cable are equipped with a standard protective rubber boot, which covers the connectors and prevents oil and dirt penetration.

The standard cable lengths for the TM0110 are 0.5m and 1.0m. Additional lengths of 5.0m and 9.0m are available with an integrated probe and extension cable connected together equaling one part.

The probe may be selected in either English or metric units, as well as, reverse mounting options.

Extension Cable – TM0181

ProvibTech's extension cable design results in better system performance and a longer life cycle.

One may select various extension cable lengths based on the probe cable length. The total length of the probe and the extension cable need to be 5m or 9m.

The connector on the extension cable is also an API 670 standard, allowing compatibility with other manufacturers' proximity probe systems.

Driver – TM0182

The TM0182 driver is used for the TM0110 proximity probe systems. The isolation from ground for the driver is a standard feature for all ProvibTech's drivers. The total length of cable between the probe and the driver should be 5m or 9m. The distance between the driver and the monitor can be up to 300m (1,000 ft). The three conductor shielded cables from the probe driver are used to connect to a vibration monitor, such as, ProvibTech's PT2060 and DM vibration monitor.

Note: Probe Driver is not required when using ProvibTech's DTM or Transmitters.



System Specifications

Electrical

Power Supply:

Voltage: -23 to -30VDC

Current: < 12mA

Linear Range:

4.0mm (160mils) begins at 0.40mm (16mils) from probe surface (AISI4140)

Range is 0.40 - 4.40mm (16 - 173 mils)

Sensitivity:

3.94 mV/um (100mV/mil)

Temperature Sensitivity:

Probe and 5 meters cable, from -30°C to 120°C, typical tolerance is within $\pm 0.4\%$ / °C reference with the middle of the linear range

Linearity (deviation from straight line):

Within $\pm 0.06\text{mm}$ (± 2.4 mil) of a straight line, if calibrated as a system. $\pm 0.16\text{mm}$ ($\pm 6.5\text{mil}$) typical including interchangeability errors

Frequency Response ($\pm 3\text{db}$):

0 - 3.0 kHz

Minimum Target Size:

33mm (1.3 inch) in diameter

Environmental

Probe Driver Temperature:

Operation: -40°C to +80°C

Storage: -50°C to +100°C

Probe Temperature:

Operation/Storage: -40°C to +177°C

Cable Temperature:

Operation/Storage: -40°C to +177°C

Humidity:

100% non-condensing

Approval:

ATEX: II 1 G, EEx ia IIC T4@Ta=-40°C~+80°C

KEMA06ATEX0217X

CSA: Intrinsically safe. ;

Class I, Div. 1, Groups A, B, C and D, T4

Class I, Zone 0, Ex ia IIC T4

Non-incentive

Class I, Div. 2, Groups A, B, C and D, T4

PCEC: Ex ia IIC T4

GOST R: 0ExialICT4X



Probe and cable approval:

ATEX: II1G, ExialICT4@Ta=-55°C~+115°C,

II2G, ExialICT2@Ta=-55°C~+232°C

KEMA07ATEX0110X

CSA: Class I, Div 1, Grps ABCD, ExialICT4

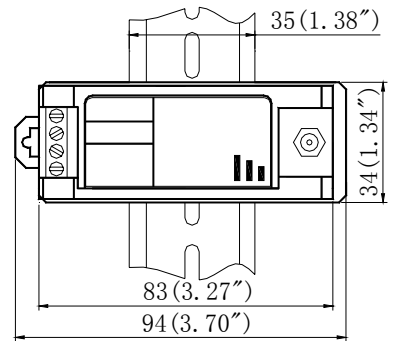

DIN Rail Mount

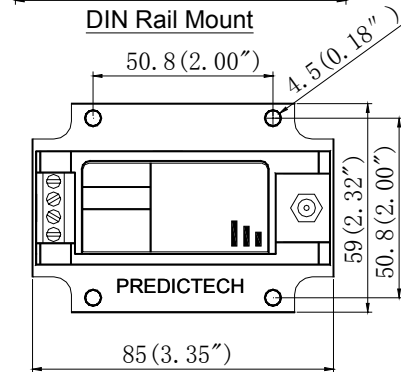

Plate Mount

Physical

Driver Height: 75mm (2.95")

Driver Mounting:

35mm DIN rail mount or Plate mount

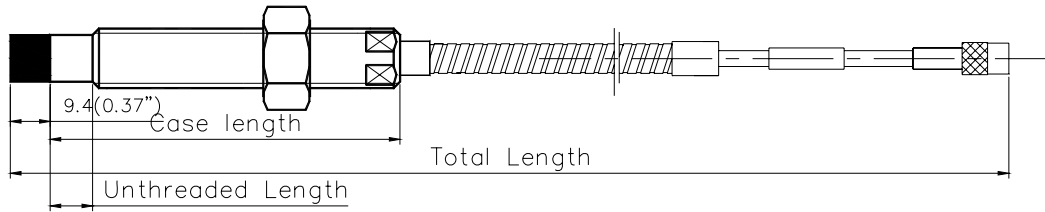

11mm Probe TM0110

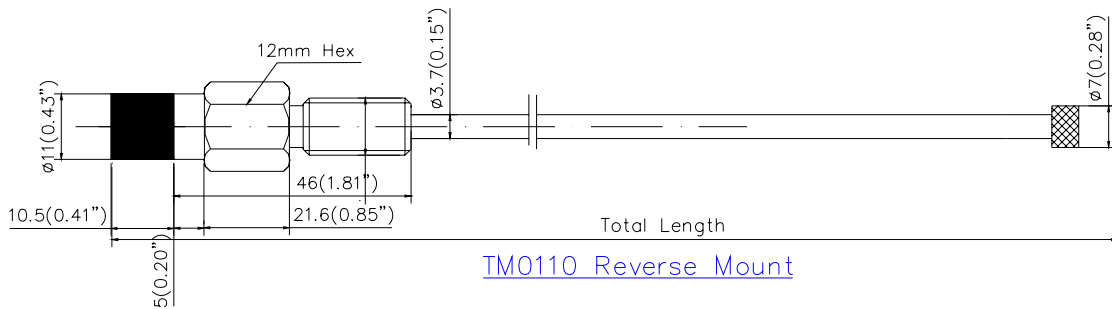

TM0110 Reverse Mount

Standard 11mm TM0110 Probes

(Works with TM0181 cable and TM0182 driver)

TM0110	-XX	-XX	-XX	-XX	-XX
Standard 11mm Probe	Probe Type	Unthreaded Length	Case Length	Total Length	Connector Type
1/2"-20UNF; without armor	-02	Standard: 00 (0.0 in) Increment: 05 (0.5 in)	Standard: 30 (3.0 in) Increment: 05 (0.5 in)	05 (0.5m) 10 (1.0m) 50 (5.0m) 90 (9.0m)	00 (none) 02 (yes)
1/2"-20UNF; with armor	-03	Maximum: Case length- 1.0 in	Minimum: 10 (1.0 in) Maximum: 95 (9.5 in)		
M14×1.5; without armor	-00	Standard: 00 (0 mm) Increment: 01 (10 mm)	Standard: 05 (50 mm) Increment: 01 (10 mm)		
M14×1.5; with armor	-01	Maximum: Case length- 20 mm	Minimum: 02 (20 mm) Maximum: 25 (250 mm)		
Reverse mount M10×1; without armor	-05	05 (5 mm)	30 (30 mm)	05 (0.5m) 10 (1.0m)	02 (yes)
Reverse mount 3/8"-24UNF; without armor	-06	02 (0.2 in)	12 (1.2 in)		



7200 Series 11mm TM0110 Probes

(Works with TM0181-24710 cables and TM0182-19049 drivers)

TM0110	-XXXXX	-XX	-XX	-XX	-XX
Standard 11mm Probe	Probe Type	Unthreaded Length	Case Length	Total Length	Connector Type
1/2"-20UNF; without armor	-19048	Standard: 00 (0.0 in) Increment: 05 (0.5 in)	Standard: 30 (3.0 in) Increment: 05 (0.5 in)	05 (0.5m) 10 (1.0m) 50 (5.0m) 90 (9.0m)	00 (none) 02 (yes)
1/2"-20UNF; with armor	-24798	Maximum: Case length- 8.0 in	Minimum: 15 (1.5 in) Maximum: 95 (9.5 in)		
M14×1.5; without armor	-26179	Standard: 00 (0 mm) Increment: 01 (10 mm)	Standard: 05 (50 mm) Increment: 01 (10 mm)		
M14×1.5; with armor	-26180	Maximum: Case length- 210 mm	Minimum: 03 (30 mm) Maximum: 25 (250 mm)		
Reverse mount 3/8"-24UNF; without armor	-29776			05 (0.5m) 10 (1.0m) 50 (5.0m) 90 (9.0m)	02 (yes)

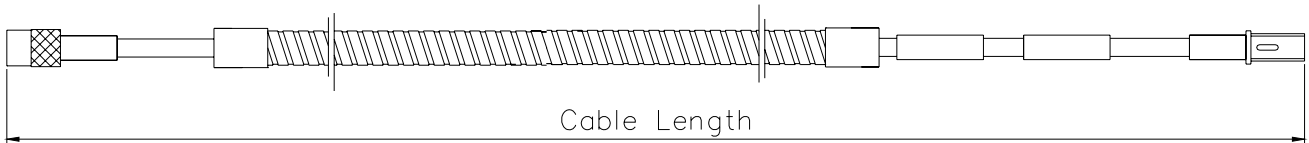

Extension Cable

Extension Cable for 11mm Probes

(Works with TM0110 probes and TM0182 drivers)

TM0181	-XXXXX	-XXX	-XX
Probe Type	Model	Cable Length	Armor
Standard 11mm probe	-	-040 (4.0 m)	-00 (No)
		-045 (4.5 m)	-01 (Yes)
7200 series 11mm probe	-24710	-080 (8.0 m)	
		-085 (8.5 m)	

Note: The total length of the probe and cable should be either 5.0 meters or 9.0 meters.



Probe Driver for 11mm Probes

(Works with TM0110 probes and TM0181 cables)

TM0182	-AXX	-BXX	-CXX
Probe Type	Cable Length	Hazardous Area Certification	Mounting
Standard 11mm probe	-A51 (standard 11mm probe, 5m) -A91 (standard 11mm probe, 9m)	-B00 (no) -B01 (multiple)	-C00 (DIN rail) -C01 (plate mount)
7200 11mm probe	-A52 (7200 11mm probe, 5m) -A92 (7200 11mm probe, 9m)		

SWANN & ASSOCIATES

562.492.1394
562.492.1396 fax
sales@swann-associates.com

1707-B East 28th Street
Signal Hill, CA 90755